

BILL OF MATERIAL		
No.	PART	MATERIAL
1	Body	Ductile Iron - ASTM A536, GR 65-45-12
2	Cover Plate	Ductile Iron - ASTM A536, GR 65-45-12
3	Flapper	EPDM w/ Ductile Iron Insert
4	O-Ring	Nitrile Rubber (Buna-N)
5	Hardware	Stainless Steel - ASTM F593, 18-8
6	Position Indicator	Stainless Steel

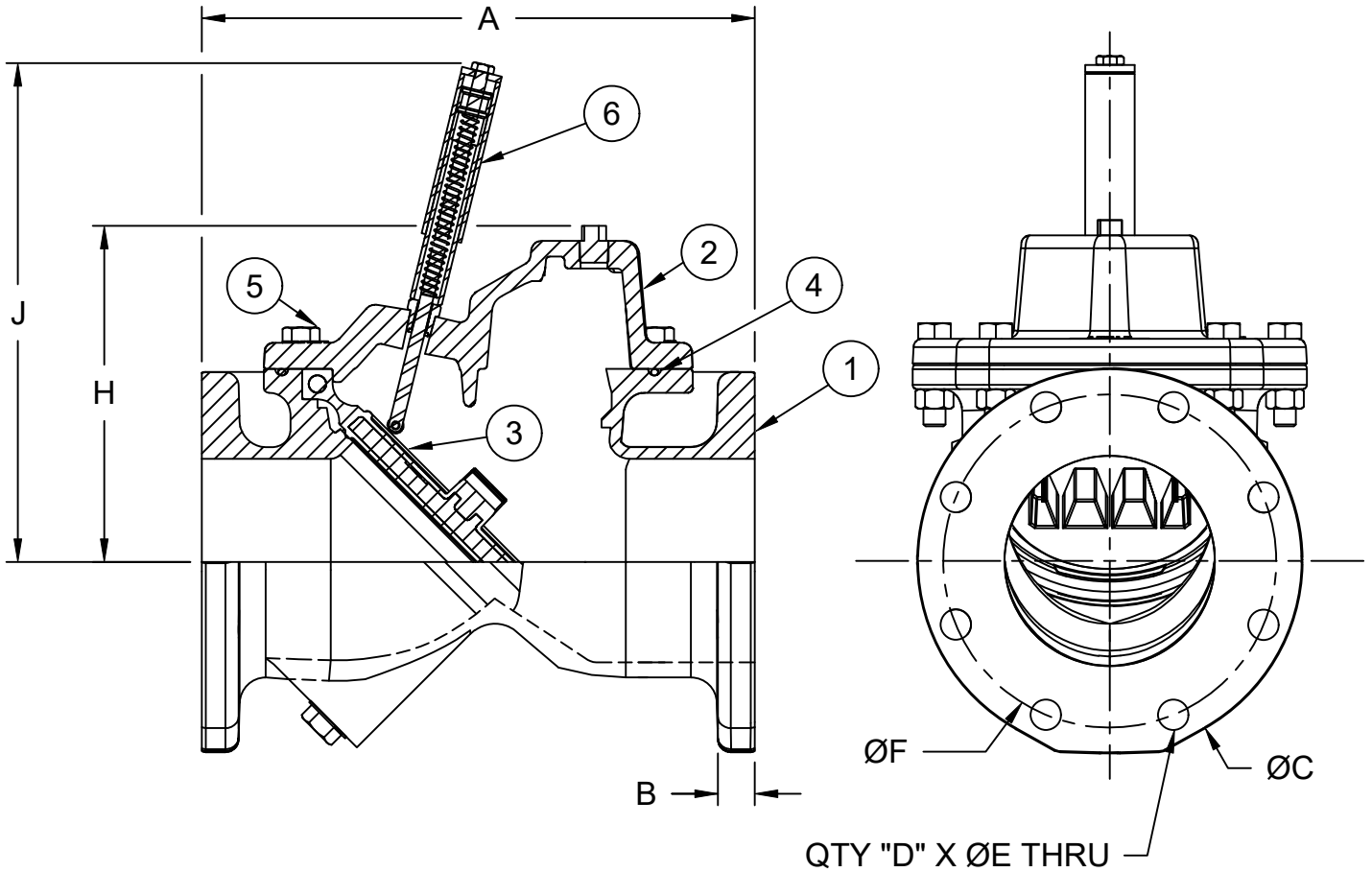

DIMENSIONS (Inches)								
SIZE	A	B	C	D	E	F	H	J
3	13.00	1.00	9.00	4	SEE NOTE	6.00	6.78	12.21
4	13.00	1.00	9.00	8	0.75	7.50	6.78	12.21
6	16.00	1.06	11.00	8	0.88	9.50	9.29	14.28
8	19.50	1.19	13.50	8	0.88	11.75	10.84	15.60
10	24.50	1.25	16.00	12	1.00	14.25	13.23	17.04
12	27.50	1.28	19.00	12	1.00	17.00	15.29	18.45

NOTE:

- 3" VALVE FLANGES DRILLED & TAPPED TO 5/8"-11 UNC-2B
- COLD WORKING PRESSURE - 250PSI
- HYDROSTATIC TEST PRESSURE - 500PSI

DESCRIPTION:

3"-12" 125# Flanged Ken-Flex Check Valve w/  
Position Indicator (Import)

DATE:

05/22/24

DRAWING:

KF-SD0003-A



McWane Plant & Industrial  
1201 Vanderbilt Road  
Birmingham, AL 35234