

KEN-FLEX™ CHECK VALVE WITH JACK SCREW

SIZES 3" - 12" DOMESTIC

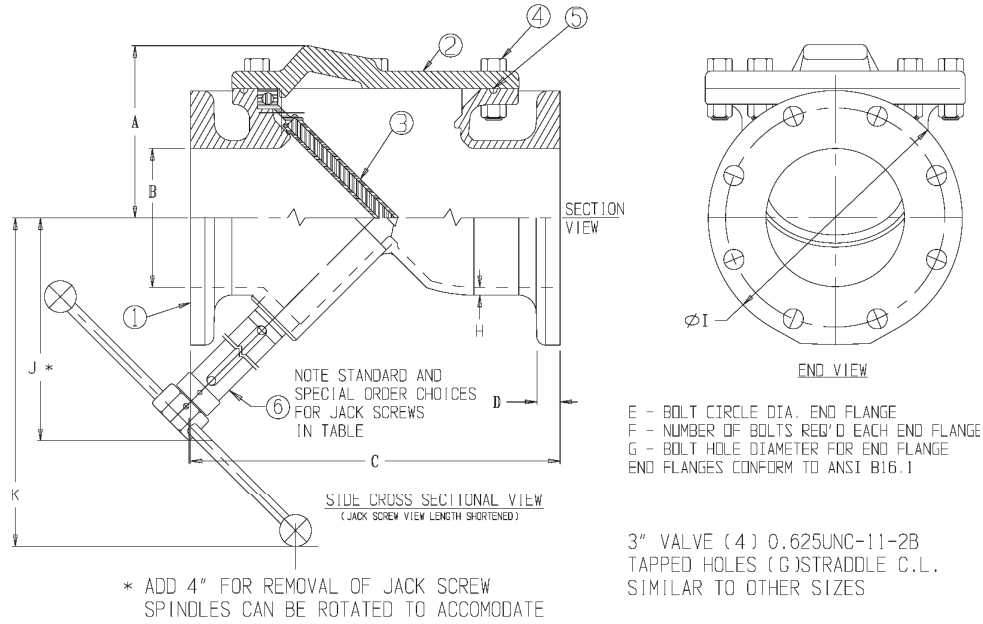

PARTS LIST			
PART No.	PART	MATERIAL	ASTM DESIGNATION
1	Body (FLG x FLG)	Ductile Iron, Coated	ASTM A536 GR 65-45-12
2	Cover Plate	Ductile Iron, Coated	ASTM A536 GR 65-45-12
3	Flapper	EPDM Flapper, Met. Insert	A536 DI/D-2000 BK 807
4	Cover Bolts & Nuts	Stainless Steel	SS 18-8 F593
5	O-Ring	Nutrilite (Buna-N)	ASTM D2000
6	Optional Jack Screws -See Note 1	Stainless Steel	N/A

NOTE 1:
 Optional Jack Screws
 4" -> 448010P (Stainless Steel)
 6"/8" -> 448106P (Stainless Steel)
 10"/12" -> 448110P (Stainless Steel)

DIMENSIONS											
SIZE	A (APPROX.)	ØB	C	D (NDM)	ØE	F	ØG	H (NDM)	I	J (APPROX.)	K (APPROX.)
3	5.37	4.00	13	1.00	6.00	4	TAP SEE ABOVE	0.31	9.0	11	15
4	5.37	4.00	13	1.00	7.50	8	0.75	0.31	9.0	11	15
6	7.45	6.00	16	1.06	9.50	8	0.88	0.34	11.0	17	21
8	8.77	8.00	19.5	1.19	11.75	8	0.88	0.34	13.5	20	24
10	10.20	10.00	24.5	1.25	14.25	12	1.00	0.38	16.0	23	28
12	11.61	12.00	27.5	1.28	17.00	12	1.00	0.41	19.0	24	29