

**BILL OF MATERIAL**

No.	PART	MATERIAL
1	Body	Ductile Iron - ASTM A536, GR 65-45-12
2	Cover Plate	Ductile Iron - ASTM A536, GR 65-45-12
3	Flapper	EPDM w/ Ductile Iron Insert
4	O-Ring	Nitrile Rubber (Buna-N)
5	Hardware	Stainless Steel - ASTM F593, 18-8
6	Jack Screw	Stainless Steel
7	Position Indicator	Stainless Steel

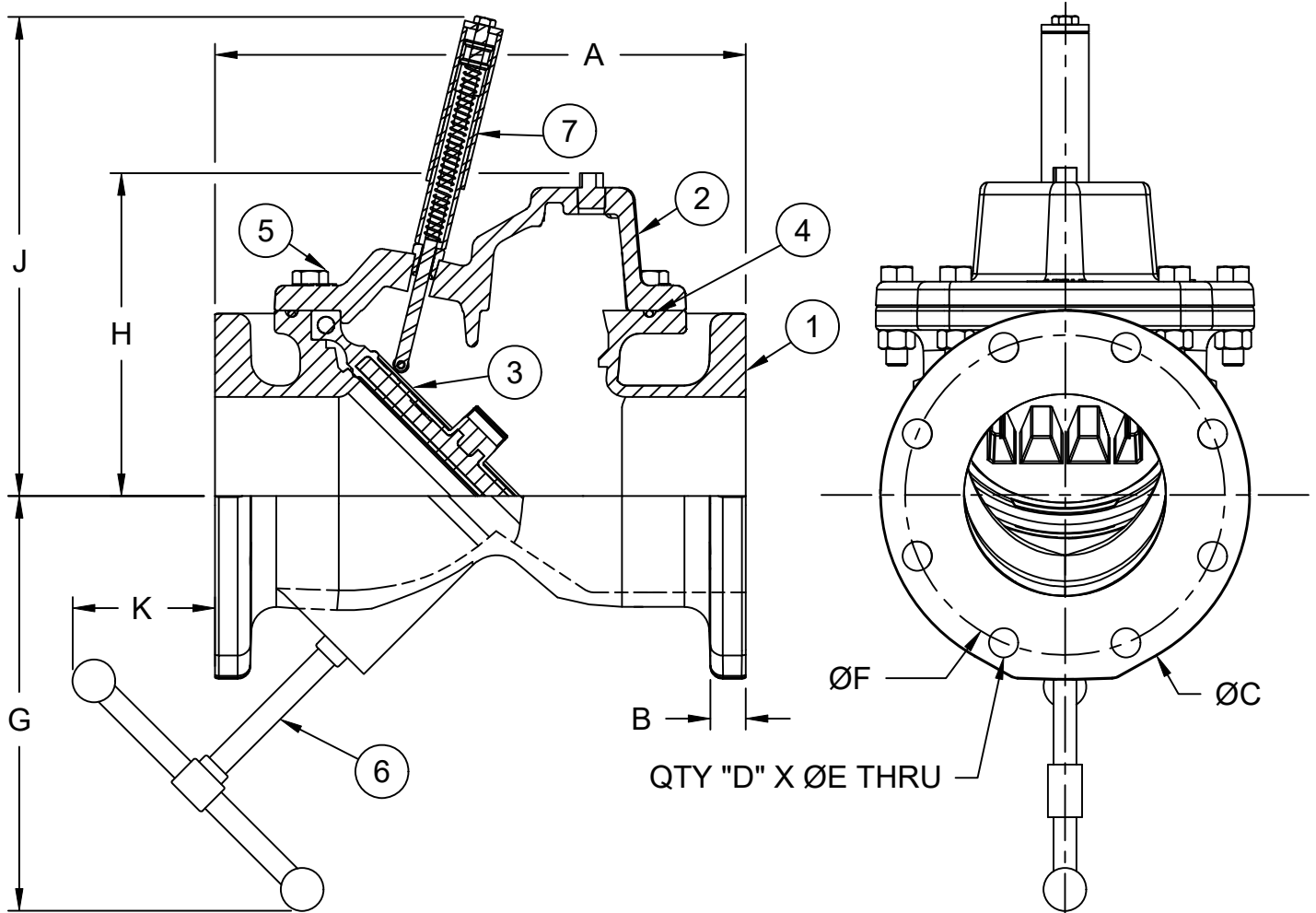

**DIMENSIONS (Inches)**

SIZE	A	B	C	D	E	F	G	H	J	K
3	13.00	1.00	9.00	4	SEE NOTE	6.00	15.00	6.78	12.21	7.79
4	13.00	1.00	9.00	8	0.75	7.50	15.00	6.78	12.21	7.79
6	16.00	1.06	11.00	8	0.88	9.50	21.00	9.29	14.28	13.17
8	19.50	1.19	13.50	8	0.88	11.75	24.00	10.84	15.60	12.56
10	24.50	1.25	16.00	12	1.00	14.25	28.00	13.23	17.04	15.81
12	27.50	1.28	19.00	12	1.00	17.00	29.00	15.29	18.45	15.81
14	31.00	1.00	21.00	12	1.13	18.75	36.10	18.00	24.20	21.80
16	32.00	1.13	23.50	16	1.13	21.25	37.60	18.93	24.60	21.30
18	36.00	1.38	25.00	16	1.25	22.75	38.70	22.03	27.80	18.70
20	40.00	1.38	27.50	20	1.25	25.00	40.60	23.28	27.90	13.90
24	48.00	1.50	32.00	20	1.38	29.50	42.90	27.63	30.30	9.00

**NOTE:**

1. 3" VALVE FLANGES DRILLED & TAPPED TO 5/8"-11 UNC-2B
2. COLD WORKING PRESSURE - 250PSI
3. HYDROSTATIC TEST PRESSURE - 500PSI

**DESCRIPTION:**

3"-24" 125# Flanged Ken-Flex Check Valve w/ Jack Screw & Position Indicator (Import)

**DATE:**

07/19/24

**DRAWING:**

KF-SD0004-B



McWane Plant & Industrial  
1201 Vanderbilt Road  
Birmingham, AL 35234