

# AA-9

## PRESSURE RELIEF VALVE

- FOR PRESSURE SETTINGS TO 120 P.S.I.
- AVAILABLE IN 6" SIZE
- CAST IRON BASE

### USES:

The Waterman Model AA-9 may be used for pressure relief on any pipeline with operating pressures up to 120 PSI where a large volume discharge is needed. The AA-9 meets the requirements of the Soil Conservation Service specifications and has a larger orifice that is a feature not found on most other makes.

### FEATURES:

Thorough engineering in the design of this unit provides for maximum volume discharge. Compare the valve opening with its nominal size, then compare with other relief valves now being sold.

Each valve is factory set and hydrostatically tested to assure accuracy. (May also be specially ordered for customer final adjustment and sealing.) Automatic operation is provided by alloy steel carbon spring, engineered and specially manufactured for these valves to provide sensitive operation and maximum volume discharge.

Materials are selected for long trouble-free "fail safe" service. A teflon seal face and bushing prevents sticking, even after long exposure to sunlight and heat. A rubber composition seal backing is cloth inserted to prevent seal "blow-out" or creep. The threaded base is high strength, close grained grey iron to eliminate thread "galling" or "freezing" which may occur with aluminum threads. Spring retainers and cover are high strength cast aluminum. Guide rod and all fasteners are stainless steel. Galvanized or plated hardware is never used.

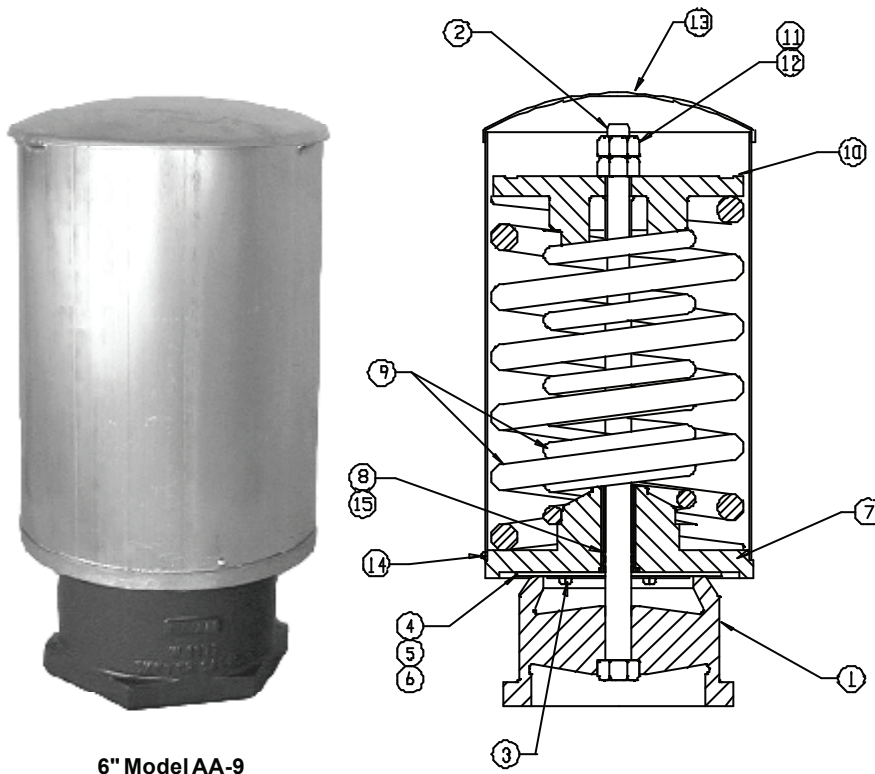

6" Model AA-9

PARTS LIST		
No.	Name	Qty.
1	Base	1
2	Stud Shaft	1
3	Screw	3
4	Gasket Retainer	1
5	Seal Face	1
6	Cover Gasket	1
7	Cover	1
8	O-Ring Seals	1
9	Coil Spring	1
10	Spring Retainer	1
11	Double Adjusting Nut	1
12	Washer	1
13	Spring Cover	1
14	Drive Screw	1
15	Teflon Bushing	1