

# AUTOMATIC SIPHONS

Waterman automatic siphons are used to remove excess inflow from basins, streams and canals, preventing overflow and flooding. High rates of discharge can be achieved for small rises in water level.

## ADVANTAGES:

- 50 times less space occupied than an overflow weir of the same capacity for the small rise in water level
- Minimum civil structure required compared to an overflow weir of the same capacity.
- Steady, progressive response with a rapid self-priming action for faster, yet uniform high volume discharge.
- Smooth and stable flow under all operating conditions without inducing surges in the system.
- Automatic, unattended operation.
- No risk of silting up.
- All-welded construction; no moving parts; no seals.



The Automatic Siphon operates as follows:

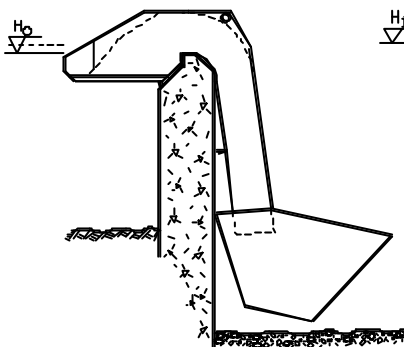

No flow until water level reaches elevation  $H_0$ .  
**STAGE 1.** Low discharge when water level reaches  $H_0$ . Siphon operates as a weir.

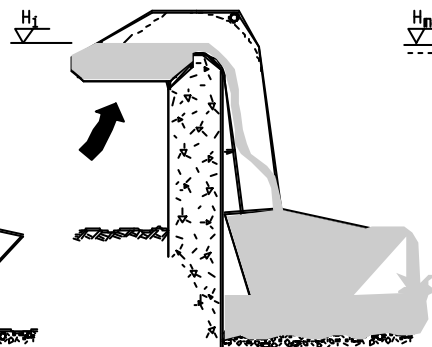

**STAGE 2.** Average discharge siphon is progressively primed, but flow is smooth and stable between  $H_0$  and  $H_{max}$ .

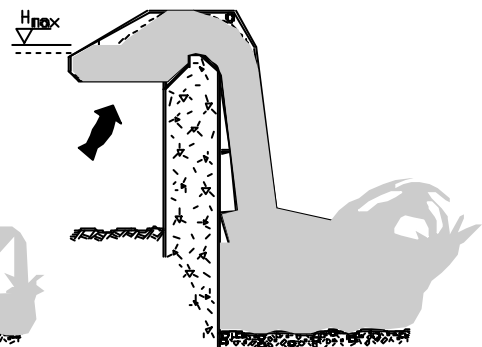

**STAGE 3.** Maximum discharge siphon is completely primed. Air inlet is covered by upstream water.

Note: This is not the usual all or nothing operation of conventional siphons. Flow is continuous and smooth.

## AUTOMATIC SIPHON APPLICATIONS

### Irrigation

- Automatic Siphons remove excess flows, protecting ditches and canals from overtopping.

### Flood Control

- Automatic Siphons can be used to increase the capacity of existing spillways on dams and reservoirs.
- By incorporating siphons into new spillways the otherwise required spillway length can be reduced resulting in considerable cost savings.

### Wastewater Treatment

- The amount of backing up of sewers in combined sewage systems can be limited by placing siphons at storm overflow outfalls.
- Flow equalization, or surge elimination, can be accomplished by using siphons in place of lengthy overflow weirs.

**STANDARD STRUCTURES**

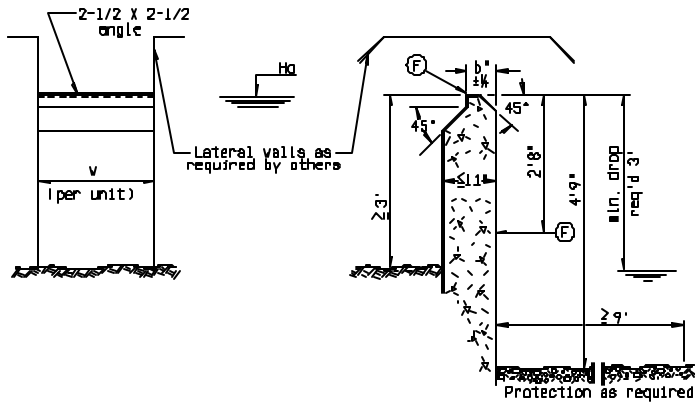

**INSTALLATION:**

ONCE THE SUPPORT IS BUILT ACCORDING TO REQUIRED DIMENSIONS. THE SIPHON IS SIMPLY LOWERED INTO POSITION. THIS ALLOWS FOR ADJUSTMENT OF THE CONTROLLED LEVEL BY ADDING OR REMOVING STOP-LOGS BENEATH THE SIPHON AND ALSO ALLOWS THE SIPHON TO BE PORTABLE.

**MATERIAL OF CONSTRUCTION:**

- MILD STEEL (GALVANIZED OR PAINTED)
- STAINLESS STEEL
- ALUMINUM

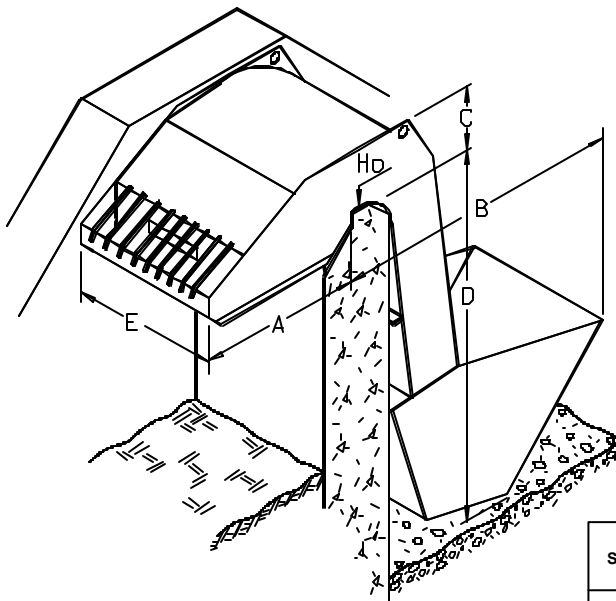
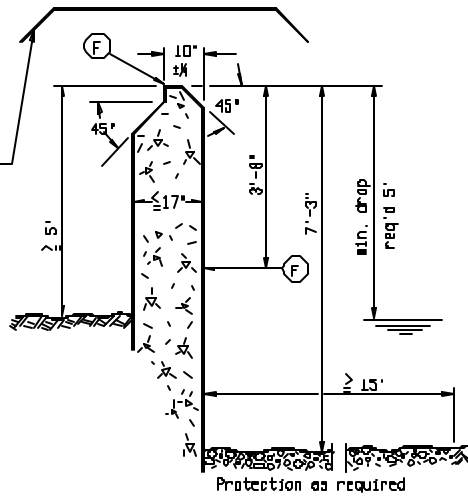
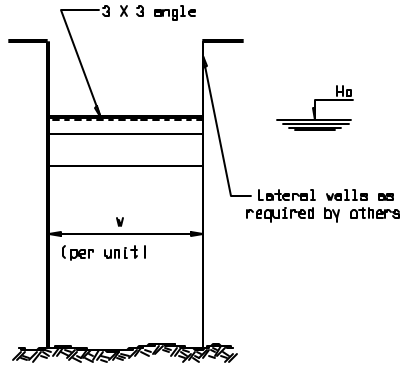

SIZE	Maximum discharge Max cfs	min. drop req'd. ft.	HMax - Ho in.	A ft. - in.	B ft. - in.	C ft. - in.	D ft. - in.	E ft. - in.	W ft. - in.	F lbs.
S3/04	4.5	3	1 1/2	2-0	3-5	0-9	4-8	0-8	0-11	300
S3/06	6.3	3	1 1/2	2-0	3-5	0-9	4-8	0-11	1-2	450
S3/09	9.0	3	1 1/2	2-0	3-5	0-9	4-8	1-3	1-6	600
S3/12	12.5	3	1 1/2	2-0	3-5	0-9	4-8	1-9	2-0	800
S5/18	18	5	2 1/4	3-4	5-10	1-3	7-2	1-2	1-5	1600
S5/25	25	5	2 1/4	3-4	5-10	1-3	7-2	1-8	1-11	2200
S5/36	36	5	2 1/4	3-4	5-10	1-3	7-2	2-4	2-7	3200
S5/50	50	5	2 1/4	3-4	5-10	1-3	7-2	3-4	3-7	4400

For larger discharges, two or more Siphons are installed side by side.

## ADVANTAGES OF SIPHONS

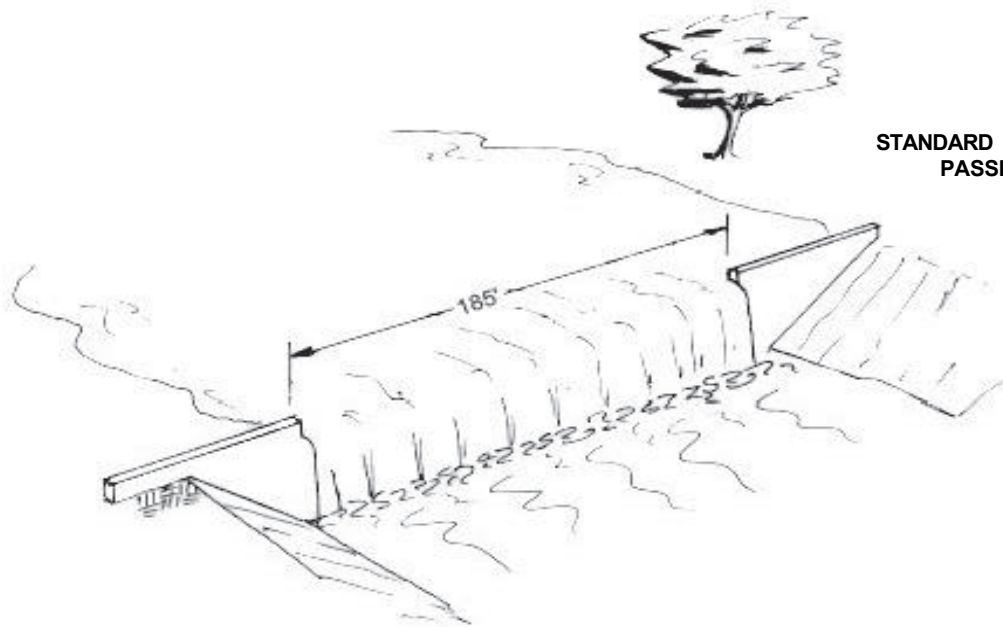

STANDARD LONG FIXED WEIR  
PASSING 50 C.F.S.

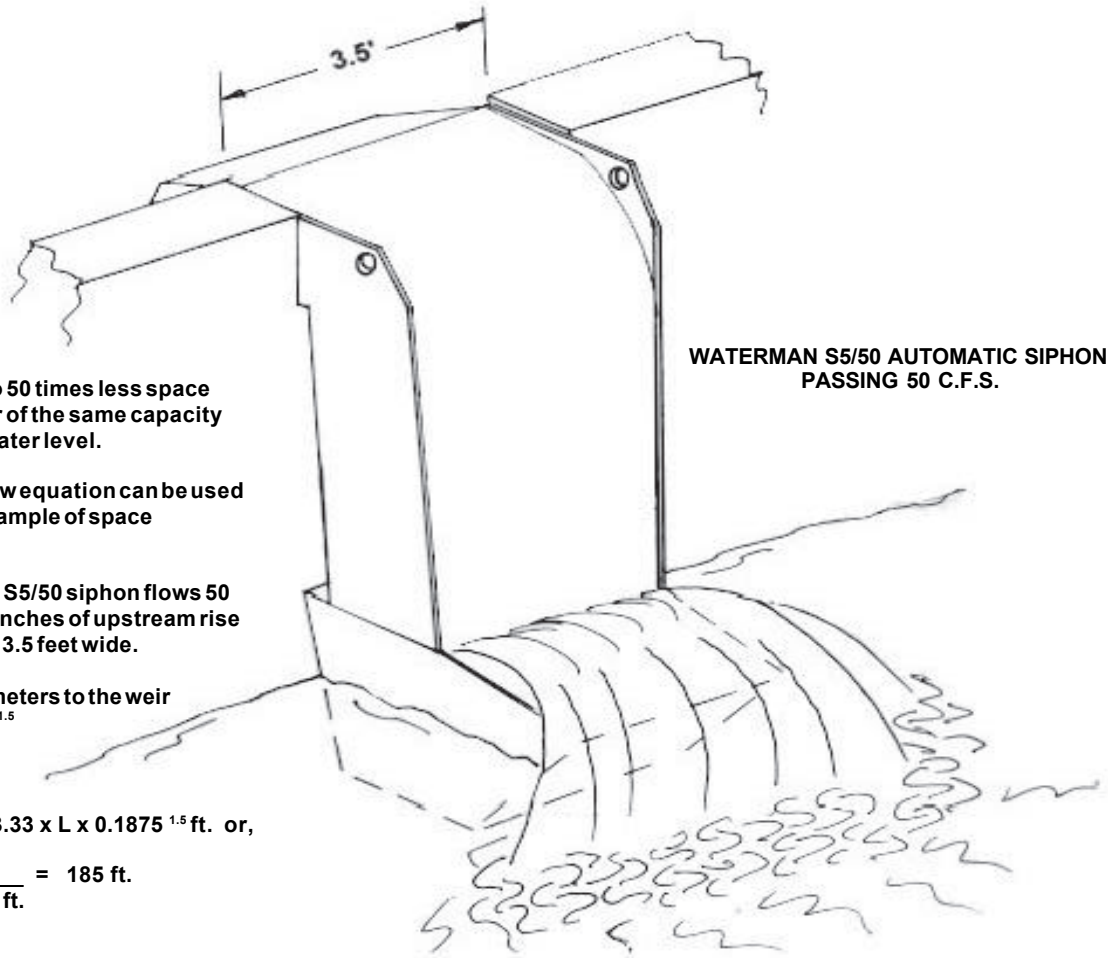

WATERMAN S5/50 AUTOMATIC SIPHON  
PASSING 50 C.F.S.

Siphons occupy 40 to 50 times less space than an overflow weir of the same capacity for the same rise in water level.

The standard weir flow equation can be used to demonstrate an example of space requirement.

The Waterman model S5/50 siphon flows 50 C.F.S. with only 2.25 inches of upstream rise and is approximately 3.5 feet wide.

Applying these parameters to the weir equation  $Q=3.33 L H^{1.5}$

yields  $50 \text{ ft}^3/\text{sec} = 3.33 \times L \times 0.1875^{1.5} \text{ ft.}$  or,

$$L = \frac{50 \text{ ft}^3/\text{sec.}}{3.33 \times 0.1875^{1.5} \text{ ft.}} = 185 \text{ ft.}$$

**Intake side of 200 CFS spillway structure with four S5/50 galvanized steel siphons.**



**Discharge side of 650 CFS spillway located on the bank of a large canal that runs through a major city. These siphons are specially outfitted with butterfly valves to provide an air inlet for throttling the flow.**

**View of the discharge side showing the sealing buckets. Sealing buckets can be detachable for convenience in transportation.**

