

QTY "N" X ØP THRU
EQUALLY SPACED ON A
ØR BOLT CIRCLE
(REFERENCE "V")

TOP FLANGE

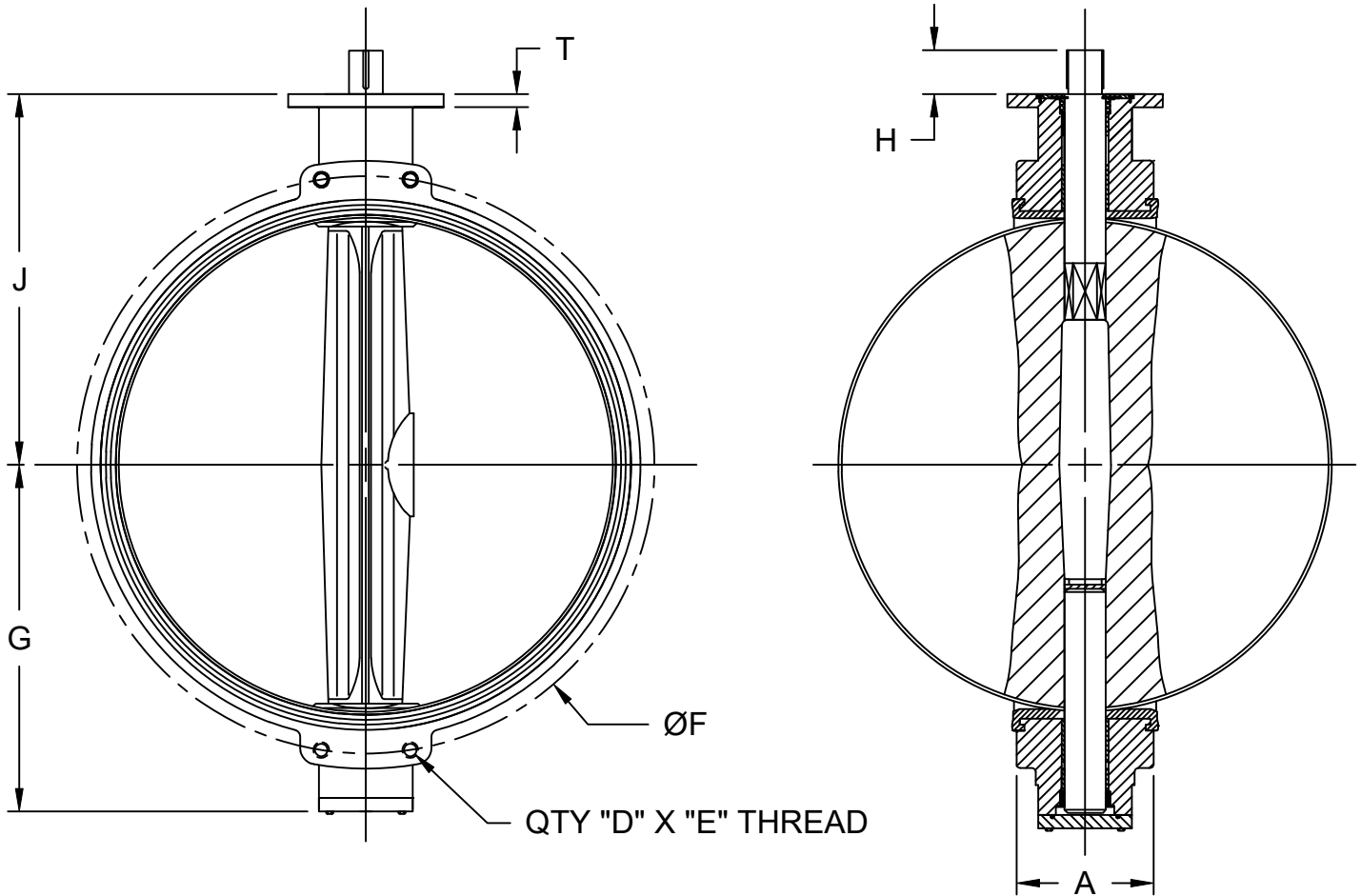

DIMENSIONS (Inches)

SIZE	A	D	E	F	G	H	J	K	M	N	P	R	S	S2	T	V	WT (lbs)
28	6.50	4	1-1/4"-8	34.00	20.08	4.33	24.57	0.709	11.81	8	0.70	10.00	2.559	2.905	1.38	F25	598
30	6.50	4	1-1/4"-8	36.00	20.08	4.33	25.60	0.709	11.81	8	0.70	10.00	2.559	2.905	1.38	F25	684
32	7.48	4	1-1/2"-8	38.50	22.84	4.33	26.46	0.709	11.81	8	0.70	10.00	2.559	2.905	1.38	F25	823
36	7.87	4	1-1/2"-8	42.75	25.04	5.12	28.35	0.787	13.78	8	0.87	11.73	2.952	3.338	1.77	F30	1,026

DESCRIPTION:
28"-36" API 609, 150# Wafer Body, Bare Shaft
Resilient Seated BFV

DATE:
08/13/2024

DRAWING:
TS-DD0011-B



McWane Plant & Industrial
1201 Vanderbilt Road
Birmingham, AL 35234