

SWING CHECK VALVE WITH LEVER AND SPRING SIZES 2" - 12"

DRAWING NO. - 54241-LS REV - 04

DRAWN BY - L2C

No.	DATE	ECN	REVISION
1	03/09	---	Release for use with 1106 valve.
2	04/18	3098	Seal gland nut replaced with stuffing box, gland, and packing.
3	07/20	2393	Reinstate S. Bux (now with O-ring), packing, gland, washers, corr. 3 lever lths.

LEVER & WEIGHT - DIMENSIONS										
	DA LG	FLG THK	FLG DD	DA HT	COVER DD	LEVER LG	CL to PIN END	PIN DIA	WALL THK	L&S WEIGHTS
SIZE	A	B	C	D	E	F	G	H	J	
2	8	0.66	6	6	6	6	4.72	0.50	0.34	39
2 ½	8.5	0.72	7	6.44	7	6	4.94	0.50	0.41	54
3	9.5	0.78	7.5	6.85	7.5	6	5.35	0.50	0.44	65
4	11.5	1.00	9	8.69	9	7.75	8.19	0.63	0.50	128
6	14	1.06	11	10.51	11	9.75	9	0.75	0.62	201
8	19.5	1.25	13.5	12.56	13.5	14.13	10.19	0.88	0.75	370
10	24.5	1.31	16	14.07	16.75	18	11.63	1.00	0.81	600
12	27.5	1.38	19	16.13	19	18	13.75	1.00	0.88	812

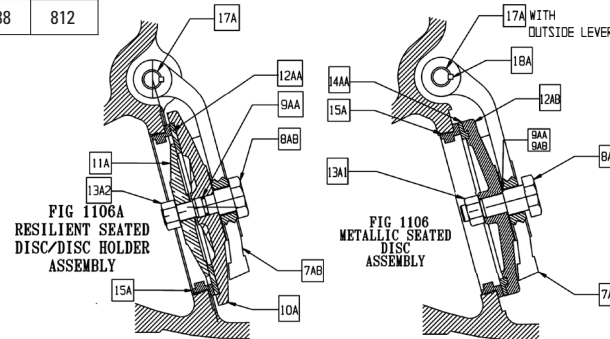
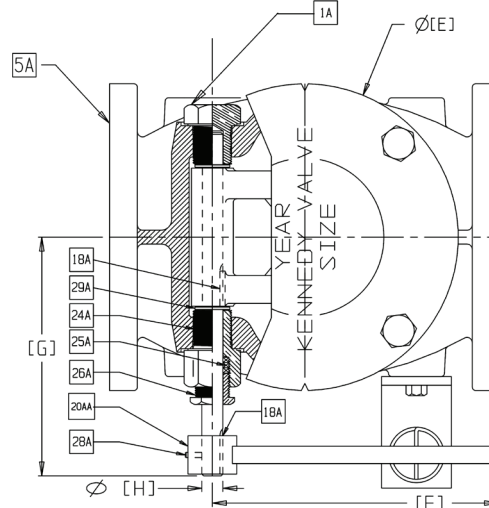
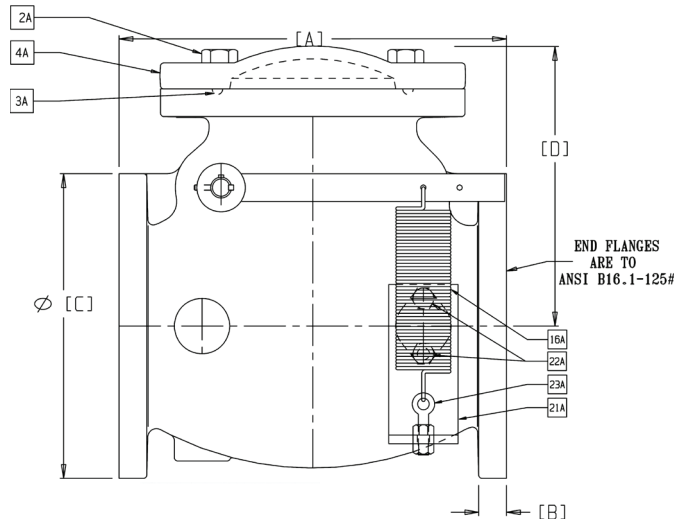

PARTS LIST		
PART No.	PART	MATERIAL & ASTM DESIG.
1A	Side Plug	Bronze B371 C69300
2A	Hex Bolt	SS18-8
3A	O-ring Seal Cover to Body	Buna-N
4A	Check Valve Cap	Gray, Cast Iron ASTM A 126B
5A	Body	Gray, Cast Iron ASTM A 126B
7AB	Keyed Hinge with Lever	Bronze (2"-3")/D.I. (4"-12")
8AA	Disc Bolt - Fig. 1106 (Metal to Metal)	Steel (4"-8")
8AA	Disc Bolt - Fig. 1106 (Metal to Metal)	Bronze (10" & 12")
8AB	Disc Bolt - Fig. 1106A (Resilient)	Bronze (4"-12")
9AA	Disc Bolt O-ring	Buna-N (10" & 12")
9AB	Disc Bolt Gasket	Fibre (4"-8")
10A	Disc Holder - Fig. 1106A	Gray, Cast Iron (4"-12", exc. 8")
10A	Disc Holder with Integral Bolt	Bronze (2"-3")
11A	Disc Plate - Fig. 1106A	Bronze
12AA	Replacable Rubber Disc - Fig. 1106A	Rubber
12AB	Disc with Integral Bronze Ring - Fig. 1106	Gray, Cast Iron (4"-12")
12AB	Disc with Integral Bolt and Ring - Fig. 1106	Bronze (2"-3")
13A1	Hex Nut-Disc - Fig. 1106	SS18-8 (2"-12")
13A2	Hex Nut-Disc Holder - Fig. 1106A	SS18-8 (2"-3")
14AA	Disc Ring Integral with Disc - Fig. 1106	Bronze (4"12")
15A	Seat Ring	Bronze B584 C89833 / C87850
16A	Spring	Steel
17A	Hinge Pin	Stainless Steel SS A-276 (304)
18A	Key	---
20AA	Lever Arm (for L/S)	Steel
21A	Bracket (for D/S)	Steel
22A	Hex Head Bolt (L/S Bracket)	Steel A307
23A	Eye Bolt w/ 2 Hex Nuts	Steel A1258
24A	Side Plug Stuffing Box	Bronze B371 C69300
25A	Packing	Non-Asbestos
26A	Gland	Stainless Steel B371 C69300
28A	Lever Set Screw	Steel
29A	Washers	Stainless Steel