

BILL OF MATERIAL

No.	PART	MATERIAL
1	Body	Ductile Iron - ASTM A536, GR 65-45-12
2	Cover Plate	Ductile Iron - ASTM A536, GR 65-45-12
3	Flapper	EPDM w/ Ductile Iron Insert
4	O-Ring	Nitrile Rubber (Buna-N)
5	Hardware	Stainless Steel - ASTM F593, 18-8

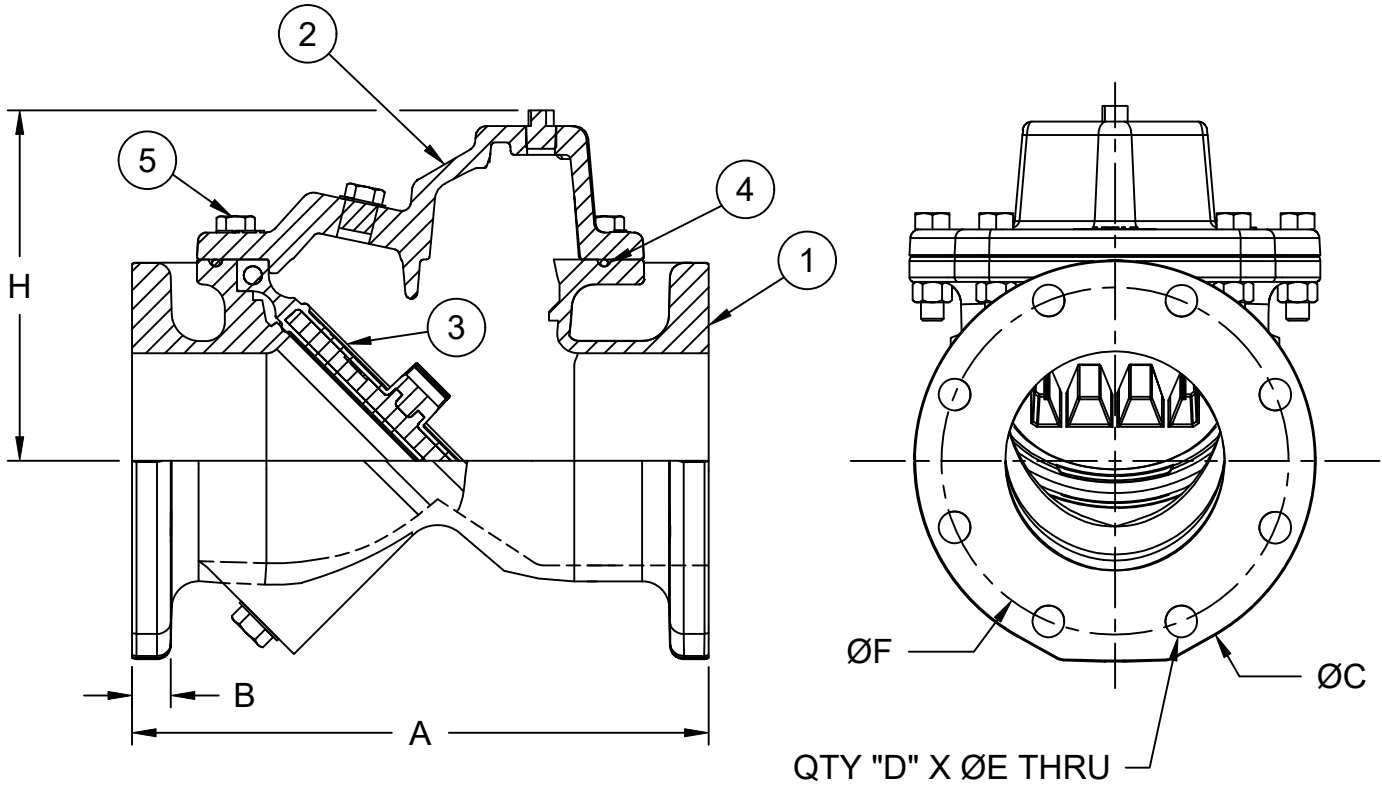

DIMENSIONS (Inches)

SIZE	A	B	C	D	E	F	H
3	13.00	1.00	9.00	4	SEE NOTE	6.00	6.78
4	13.00	1.00	9.00	8	0.75	7.50	6.78
6	16.00	1.06	11.00	8	0.88	9.50	9.29
8	19.50	1.19	13.50	8	0.88	11.75	10.84
10	24.50	1.25	16.00	12	1.00	14.25	13.23
12	27.50	1.28	19.00	12	1.00	17.00	15.29
14	31.00	1.00	21.00	12	1.13	18.75	18.00
16	32.00	1.13	23.50	16	1.13	21.25	18.93
18	36.00	1.38	25.00	16	1.25	22.75	22.03
20	40.00	1.38	27.50	20	1.25	25.00	23.28
24	48.00	1.50	32.00	20	1.38	29.50	27.63

NOTE:

- 3" VALVE FLANGES DRILLED & TAPPED TO 5/8"-11 UNC-2B
- COLD WORKING PRESSURE - 250PSI
- HYDROSTATIC TEST PRESSURE - 500PSI

DESCRIPTION:

3"-24" 125# Flanged Ken-Flex Check Valve

DATE:

05/22/24

DRAWING:

KF-SD0001-A



McWane Plant & Industrial
1201 Vanderbilt Road
Birmingham, AL 35234

