

PF-25 FLAP VALVE

SIZES 4" TO 24", FLANGE OR WALL MOUNTING,
FOR DRAINAGE OR PUMP DISCHARGE

FEATURES

- Suitable for 25-foot seating head
- 7.5-degree angle ensures positive closure
- ANSI 125# flanged connection
- Iron cover with neoprene seat

OPTIONS

- Counterweight options - consult factory

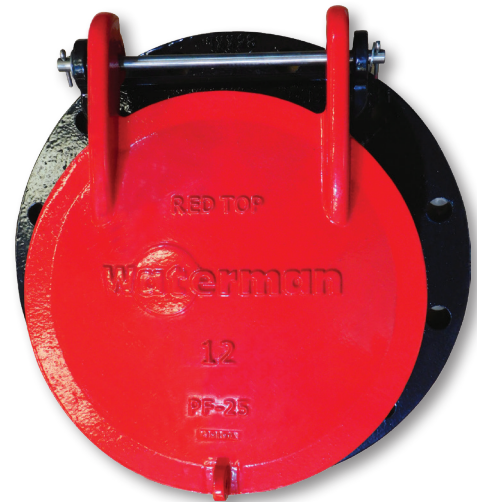

MATERIALS OF CONSTRUCTION		
Number	Name	Material
1	Frame	Cast Iron ASTM A126 Class B
2	Cover	Cast Iron ASTM A126 Class B
3	Hinge Pin	Stainless Steel 316
4	Washer	Stainless Steel 316
5	Spring Pin	Stainless Steel 316
6	Seat	Neoprene ASTM D-2000

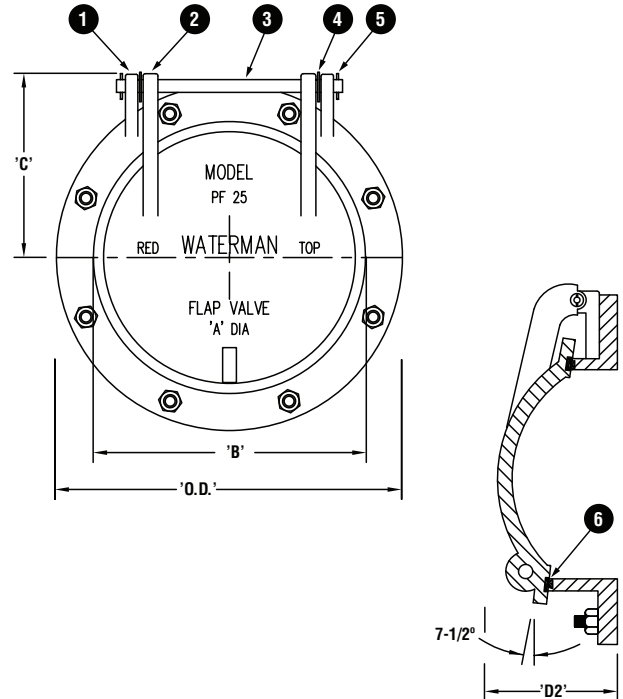

PF-25 FLAP VALVE

SIZES 4" TO 24", FLANGE OR WALL MOUNTING,
FOR DRAINAGE OR PUMP DISCHARGE

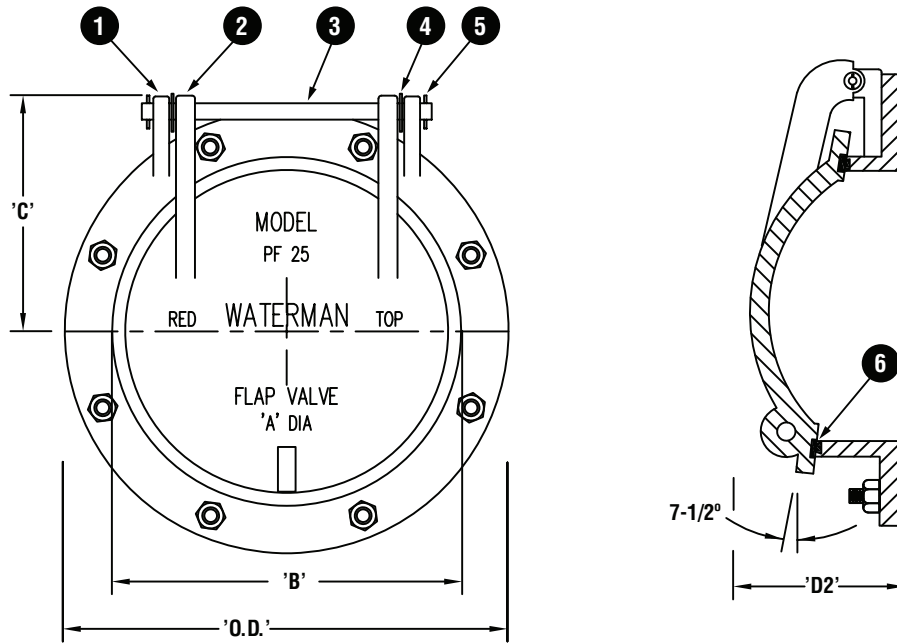

DIMENSIONS FOR FLANGE BACK

Size	C	D2	O.D.
4	4 5/8	6 1/4	9
6	5 11/16	7 5/8	11
8	6 7/8	8	13 1/2
10	8 1/8	8	16
12	9 3/8	8 1/2	19
14	10 7/16	10 1/2	21
16	11 5/8	10 1/2	23 1/2
18	12 1/8	10 1/2	25
20	13 3/8	11	27 1/2
24	15 1/2	11	32

PARTS LIST

Number	Name
1	Frame
2	Cover
3	Hinge Pin
4	Washer
5	Spring Pin
6	Seat